



FR1003 RGB Special Effects Integrated Circuit (IC)

The FR1003 is an advanced special effects integrated circuit (IC) designed to control RGB LEDs. The FR1003 provides a wide range of special lighting effects including multiple brightness levels, colors, flashing modes, strobe effects, pulsing effects, and fade effects. A single pushbutton connected to the IC allows the user to cycle through all the various output modes as well as turn the IC ON and OFF.

Features

- Operates from 4.5 to 5.5VDC
- Compatible with most logic-level N-channel MOSFET transistors
- Designed for driving single LEDs and RGB LEDs
- Single pushbutton allows user to cycle through modes
- Internal memory remembers last setting when power is removed
- Available in industry standard DIP-8 and SOIC-8 packages
- (26) Modes of operation
- Custom programming is available (Please contact us for additional information)

Pin Descriptions

Pin Number	Function
1	Vcc – Connect to 4.5 to 5.5V power source
2	No connection
3	No connection
4	No connection
5	Output – Drives logic-level N-Channel MOSFETs
6	NC
7	NC
8	Gnd – Connect to ground

Operation

A single pushbutton is used to change both the operational mode of the IC, stop and start the display animations, and enable and disable the output. The following table outlines all the different functions of the IC as they are controlled via the pushbutton.

Pushbutton Action	Function
PB single press	Starts the display animation if paused Pauses the display animation if running
PB double press	Cycles to the next operational mode
PB long press	Toggles the output ON / OFF



Default Modes of Operation

The following table outlines the various modes of operation of the FR1003. Please note, we can custom program the FR1003 with any RGB sequence, color combination, and timing pattern, that is required. Please contact our sales department for additional information.

Mode Number	Operation
1,2	Red, Pulsating (slow, fast)
3,4	Green, Pulsating (slow, fast)
5,6	Blue, Pulsating (slow, fast)
7,8	White, Pulsating (slow, fast)
9,10,11	White, Steady (high, med, low)
12	Red, Steady
13	Green, Steady
14	Blue, Steady
15	Yellow, Steady
16	Magenta, Steady
17	Cyan, Steady
18	RGB Cycle Mode 1 (continuously color fade change)
19	RGB Cycle Mode 2 (continuously color fade change)
20,21,22	Strobe Red, Green, Blue (fast, med, slow)
23	Strobe Red, Fast
24	Strobe White, Fast
25,26	Police Strobe Red, Blue (fast, slow)
OFF	

Typical Application

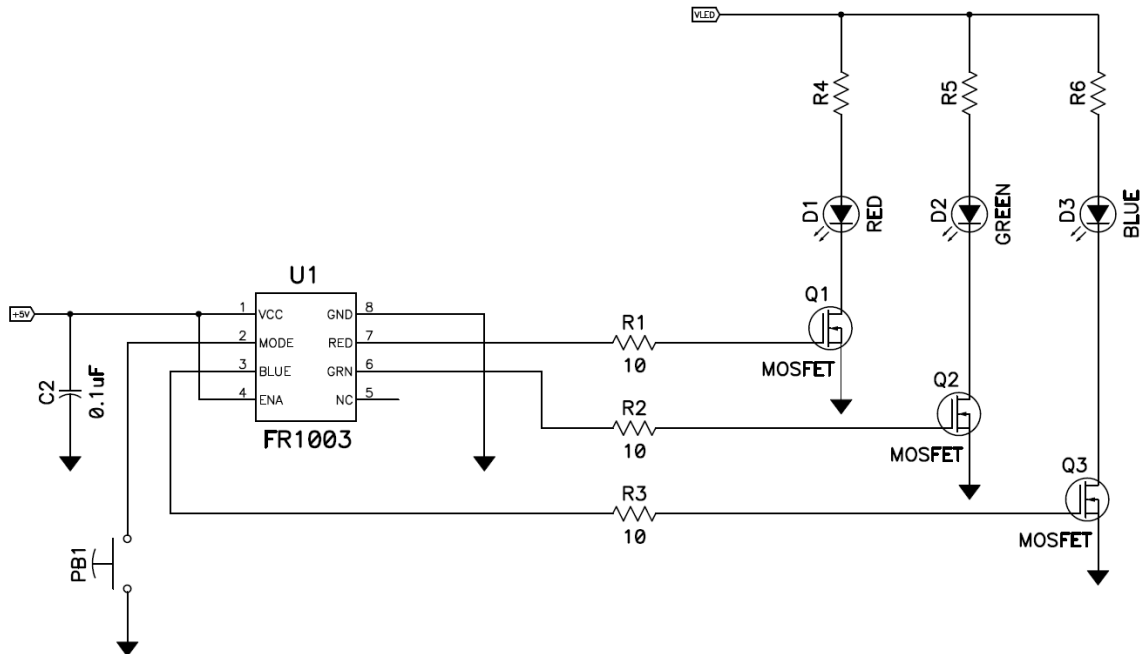

Note: A 0.1µF bypass ceramic capacitor is required.